

A	
??? (Applied DRAW. No.)	
?? ?? (DRAW. No.)	? ? (Remarks)
1	
2	

C		D	
MARK	DATE	DETAIL OF REVISION	CHECK APP.
△			
△			

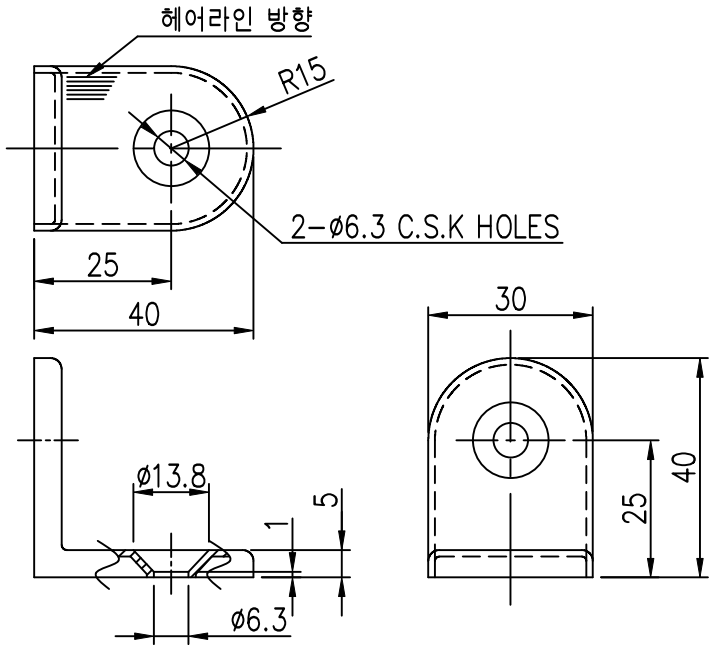

GENERAL TOLERANCE

DIVISION	GRADE	LEVEL		
		A LEVEL	B LEVEL	C LEVEL
1-4		±0.05	±0.10	±0.25
4-16		±0.07	±0.20	±0.35
16-63		±0.10	±0.30	±0.50
63-250		±0.18	±0.55	±0.90
250-500		±0.30	±0.90	±1.50
500-1000		±0.50	±1.50	±2.50

?? ?	??	? ?	??	? ?	? ?	? ?
Part No.	No.	Part Name	Qt'y	Material	Remarks	
DRAWN	CHECKED	CHECKED	APPROVED	SCALE: 1/1		
				UNIT: MM	TITLE:	
			SIZE: A3	THIRD ANGLE PROJECTION	MODEL No.	
			DATE :	DWG No.		